

Submit 1 Copy To Appropriate District Office
 District I – (575) 393-6161
 1625 N. French Dr., Hobbs, NM 88240
 District II – (575) 748-1283
 811 S. First St., Artesia, NM 88210
 District III – (505) 334-6178
 1000 Rio Brazos Rd., Aztec, NM 87410
 District IV – (505) 476-3460
 1220 S. St. Francis Dr., Santa Fe, NM 87505

State of New Mexico
 Energy, Minerals and Natural Resources

Form C-103
 Revised July 18, 2013

OIL CONSERVATION DIVISION
 1220 South St. Francis Dr.
 Santa Fe, NM 87505

SUNDRY NOTICES AND REPORTS ON WELLS (DO NOT USE THIS FORM FOR PROPOSALS TO DRILL OR TO DEEPEN OR PLUG BACK TO A DIFFERENT RESERVOIR. USE "APPLICATION FOR PERMIT" (FORM C-101) FOR SUCH PROPOSALS.)		WELL API NO. 30-015-23520
1. Type of Well: Oil Well <input type="checkbox"/> Gas Well <input checked="" type="checkbox"/> Other		5. Indicate Type of Lease STATE <input type="checkbox"/> FEE <input checked="" type="checkbox"/>
2. Name of Operator Marathon Oil Permian LLC		6. State Oil & Gas Lease No.
3. Address of Operator 990 Town & Country Blvd. Houston, TX 77024		7. Lease Name or Unit Agreement Name Harroun Com
4. Well Location Unit Letter <u>B</u> : <u>660</u> feet from the <u>FNL</u> line and <u>1980</u> feet from the <u>FEL</u> line Section <u>33</u> Township <u>22S</u> Range <u>28E</u> NMPM County <u>EDDY</u>		8. Well Number <u>1</u>
11. Elevation (Show whether DR, RKB, RT, GR, etc.) 3064' GL		9. OGRID Number 372098
10. Pool name or Wildcat Dublin Ranch; Morrow (Gas)		

12. Check Appropriate Box to Indicate Nature of Notice, Report or Other Data

NOTICE OF INTENTION TO: PERFORM REMEDIAL WORK <input type="checkbox"/> PLUG AND ABANDON <input type="checkbox"/> TEMPORARILY ABANDON <input checked="" type="checkbox"/> CHANGE PLANS <input type="checkbox"/> PULL OR ALTER CASING <input type="checkbox"/> MULTIPLE COMPL <input type="checkbox"/> DOWNHOLE COMMINGLE <input type="checkbox"/> CLOSED-LOOP SYSTEM <input type="checkbox"/> OTHER: <input type="checkbox"/>		SUBSEQUENT REPORT OF: REMEDIAL WORK <input type="checkbox"/> ALTERING CASING <input type="checkbox"/> COMMENCE DRILLING OPNS. <input type="checkbox"/> P AND A <input type="checkbox"/> CASING/CEMENT JOB <input type="checkbox"/> OTHER: <input type="checkbox"/>	
		Notify OCD 24 hrs. prior to any work done	

13. Describe proposed or completed operations. (Clearly state all pertinent details, and give pertinent dates, including estimated date of starting any proposed work). SEE RULE 19.15.7.14 NMAC. For Multiple Completions: Attach wellbore diagram of proposed completion or recompletion.

1. Comply with all company and governmental safety regulations.
2. Pump kill wt fluid down tbg/csg to kill well.
3. ND tbg spool adaptor.
4. Install 2 way check valve in profile of tbg hanger.
5. Install pup jt in profile of tbg. Screw on TIW valve on top of pup jt.
6. Attempt to change pin in hanger bolt. If unsuccessful, prep to TOH w/ tbg and TA well.
7. MIRU WOR. NU BOPs
8. TOH w/ 2-7/8" tbg and lay down tbg.
9. RIH w/ JB/GR to 12,150' inside 5" 18# N-80 csg liner.
10. RIH w/ 5" CIBP to 12,150'. Pressure test plug to 500# for 1 hr.
11. Dump Bail 35' Class H cmt on top of plug.
12. RDMO.

TA status may be granted after a successful MIT test is performed. Contact the OCD to schedule the test so it may be witnessed.

Spud Date:

Rig Release Date:

I hereby certify that the information above is true and complete to the best of my knowledge and belief.

SIGNATURE Adrian Covarrubias TITLE Regulatory Compliance Representative DATE 11/14/2022

Type or print name Adrian Covarrubias E-mail address: acovarrubias@marathonoil.com PHONE: 713-296-3368

For State Use Only

APPROVED BY: [Signature] TITLE Staff Manager DATE 11/14/22
 Conditions of Approval (if any):

Harroun Com 1
CURRENT WBD

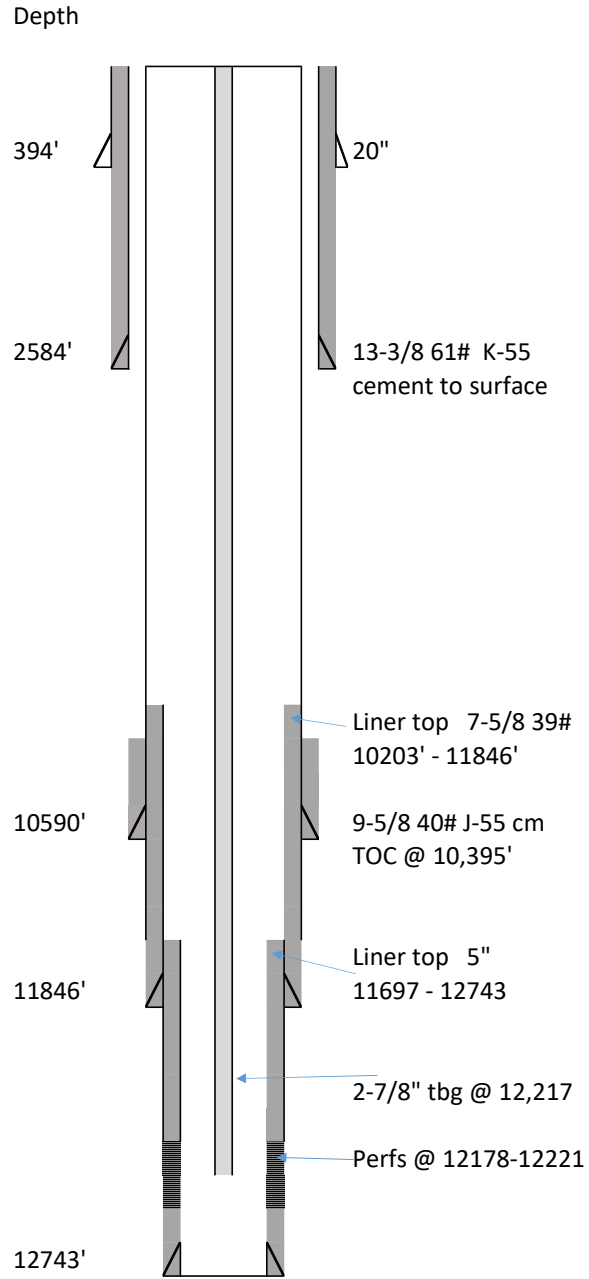

Harroun Com 1
Proposed WBD

